

NOTES

All dimensions in millimetres.

Fencing to be to BS.1722:Part 7.2006
Type SPR 13/4 (4 rail), unless
as otherwise stated below.

Dimensions (mm)

Main post	2100 x 75 x 150
Rails	38 x 87

If posts are to be driven,
the butt end shall be pointed
for 225mm. If posts are not
driven, the post holes shall be
carefully backfilled and rrammed
as filling proceeds.

Rails shall be butt jointed
on the centreline of posts.
Joints shall be staggered so
that alternate joints occur on
one post. Rails shall be nailed
to the posts with two nails
at each end and in the middle.

Nails shall be 100mm. x 4mm.
to BS 1202-1 and hot dip
galvanised to BS EN ISO 1461

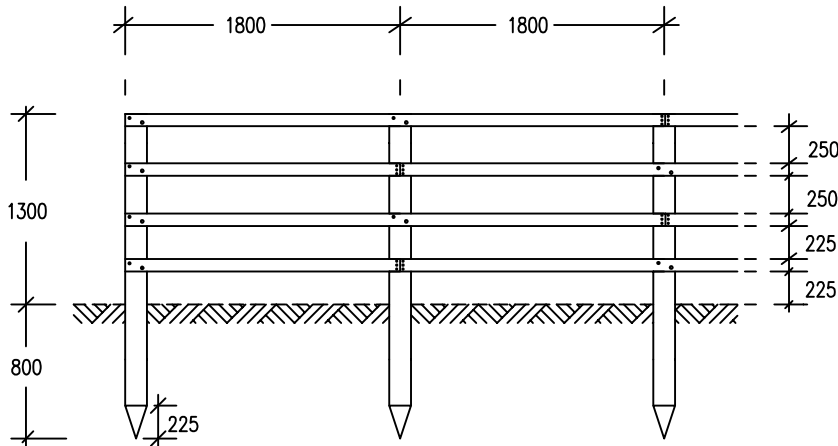

ELEVATION

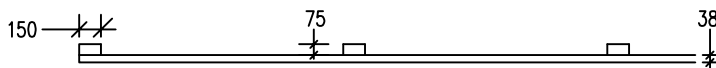

PLAN