

ELEVATION

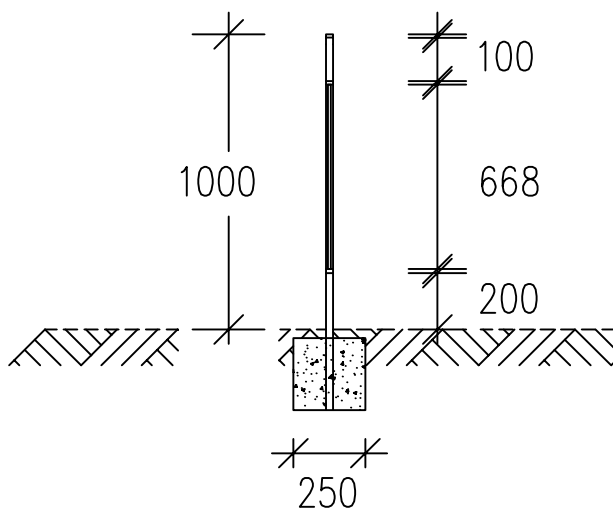

SECTION

NOTES

All dimensions in millimetres.

All members shall be of mild steel solid bar.

Dimensions (mm)

Posts	1338 x 25 x 25
Top Rail	40 x 12
Intermediate rails	30 x 10
Vertical spar	668 x 15 x 15

All joints shall be continuously welded, with a minimum throat thickness of 5mm.

Joints in the top rail shall be ground flush. All corners and edges shall be ground to a minimum radius of 5mm and be smooth.

Site welded joints shall be cleaned and primed.

Standard finish hot dip galvanised to BS.EN.ISO.1461:2009

Mix ST4 concrete to be used in all foundations.

At free ends, the top rail shall be curved at 100mm radius, and be flush with the outer face of the end post.

Reinstatement to base of posts to be as existing surfacing.