

NOTES

All dimensions in millimetres.

Quadrant details to comply with BS.EN.1340:2003

Quadrant size 305mm. x 255mm.

Quadrants to be hydraulically pressed.

Quadrant found and haunch to be mix ST4 concrete.

Quadrants to be laid and bedded on a layer of designation (i) mortar not less than 10mm. and not more than 40mm. thick. Alternatively, quadrants may be laid directly on the concrete foundation while it is still plastic.

Kerbs shall be abutted to quadrants except those which are mitred. These shall be laid with an average gap of 6mm. and pointed with designation (i) mortar.

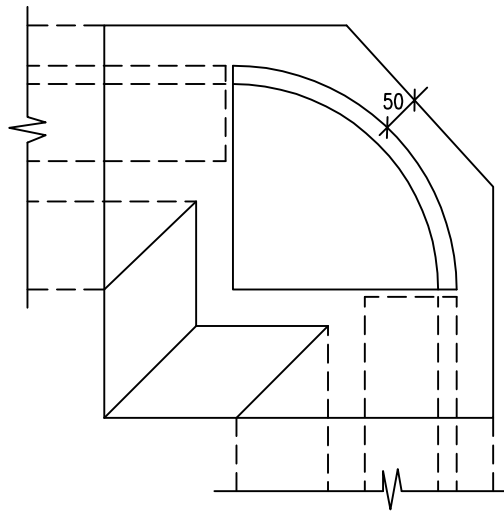

PLAN

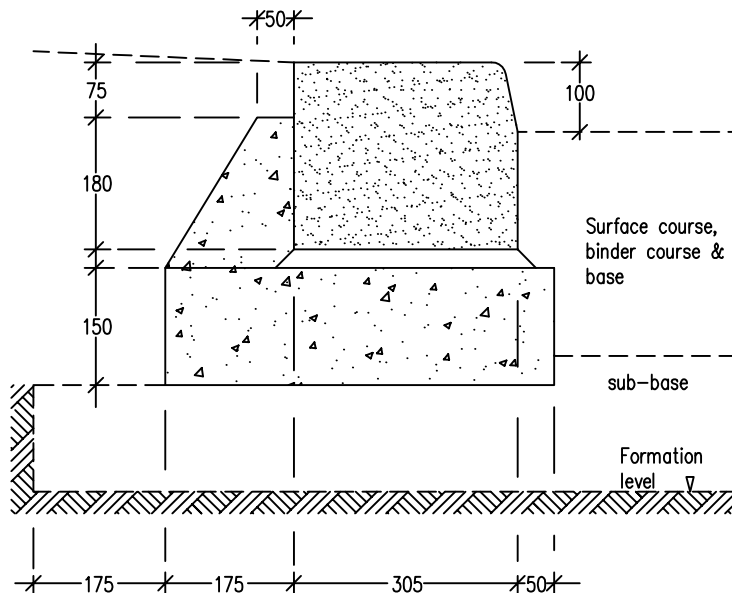

SECTIONAL ELEVATION